



AN-SOF v2.6

Antenna Simulation Software

Golden Engineering

www.antennasoftware.com.ar

General Description

- ◆ **AN-SOF** is the *easiest to use* software for the simulation of wire antennas and, at the same time, it is the *most accurate one*.



AN-SOF v2.6 Antenna Simulation Software

- ◆ **Key Advantages**

- **Fast and easy input and output graphical interfaces.**
- **Exact description of geometry details.**
- **Extended frequency range.**
- **MATLAB® Component Runtime for higher accuracy and speed.**

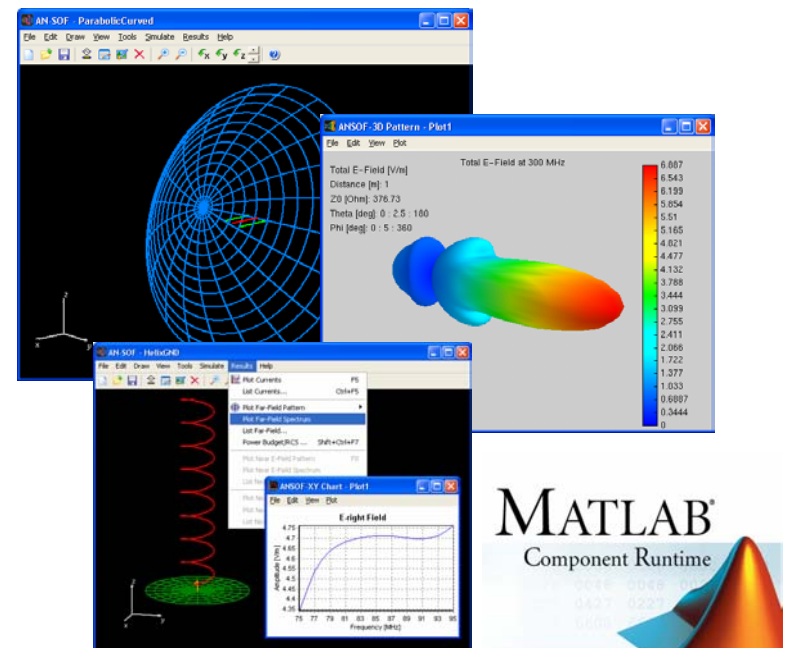

Fundamentals of Simulation

- ◆ **AN-SOF** computes the electric currents flowing on metallic structures.
- ◆ Any metallic structure is modeled using conductive wires.
- ◆ Antennas, transmission lines and waveguides are metallic structures that can be modeled using AN-SOF.
- ◆ The electromagnetic fields radiated by the electric currents flowing on wire structures are also computed.
- ◆ Transmitting and receiving antennas can be analysed and designed.

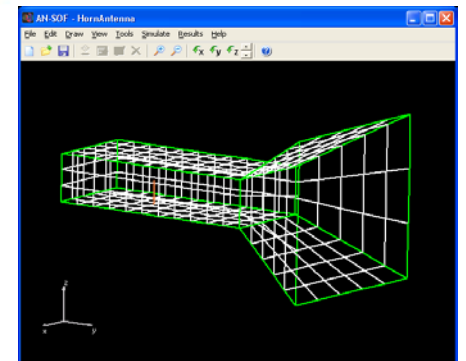
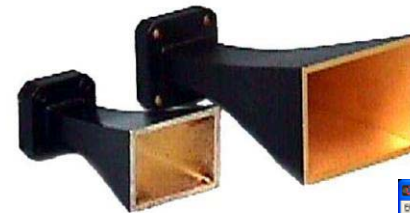
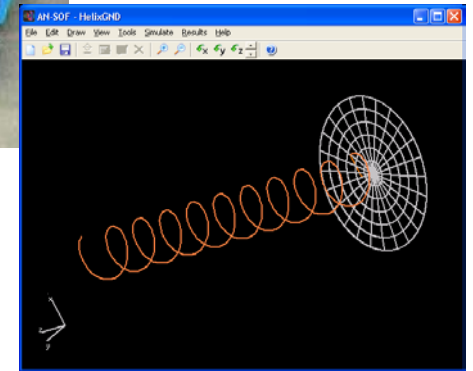
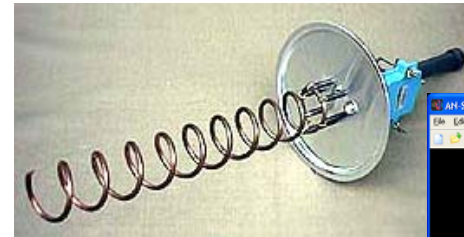

Method of Moments

- ◆ The **Method of Moments (MoM)** is a numerical technique for the calculation of electric currents flowing on metallic structures.
- ◆ The wire structure is divided into *segments*. Segment length must be short compared to the wavelength.
- ◆ In the *traditional MoM*, segments are considered to be *straight wires*, so a linear approximation to geometry details is used.
- ◆ The current in each segment is obtained by solving an integral form of Maxwell equations in the *frequency domain*. A matrix equation is obtained when segmentation is applied.

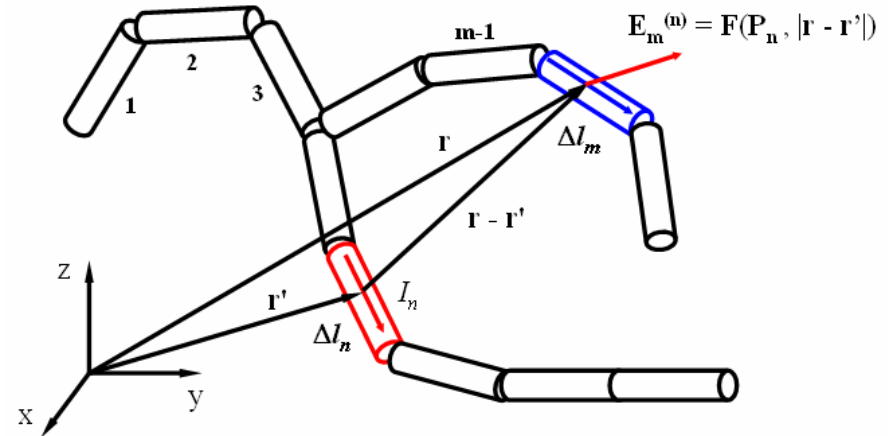

$$\begin{bmatrix} V_1 \\ V_2 \\ \dots \\ V_N \end{bmatrix} = \begin{bmatrix} Z_{11} & Z_{12} & \dots & Z_{1N} \\ Z_{21} & Z_{22} & \dots & Z_{2N} \\ \dots & \dots & \dots & \dots \\ Z_{N1} & Z_{N2} & \dots & Z_{NN} \end{bmatrix} \begin{bmatrix} I_1 \\ I_2 \\ \dots \\ I_N \end{bmatrix}$$

Limitations of Traditional MoM

- ◆ The straight wire approximation often requires a *very large number of segments* to adequately approximate *curved geometries*. Poor convergence of results is obtained for helical, loop and spiral antennas.
- ◆ Convergence problems arise for *bent wires at right angles* and for angles less than 30 degrees.
- ◆ Wires cannot be *very close* to each other. Misleading results are obtained when the separation between wires is less than a quarter of a segment length.

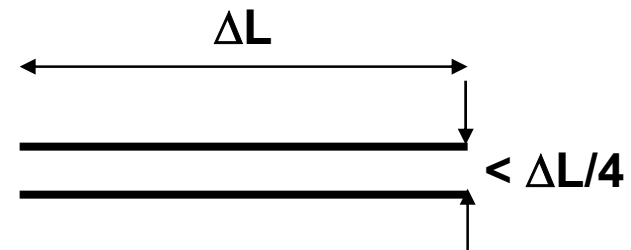
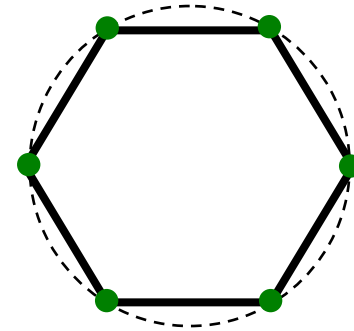

Curved MoM

- ◆ An innovative MoM is used in **AN-SOF**: the **Curved Method of Moments (CMoM)**.
- ◆ In the CMoM, *conformal segments* are used which exactly follow the contour of the structure, so an **exact description of geometry details** is obtained.
- ◆ The limitations for bent wires and wire separation are removed by means of improved numerical techniques for solving integrals and matrix equations via **MATLAB® Component Runtime**.
- ◆ **AN-SOF** is the *only* software that implements the **CMoM**.

Traditional Method of Moments

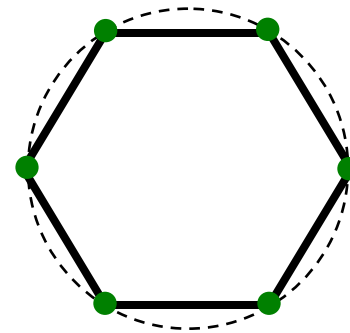

Curved Method of Moments

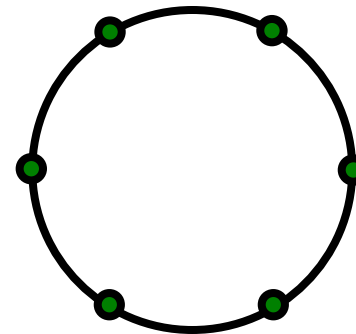

Advantages of CMoM

- ◆ Using curved segments, the number of calculations is reduced and *accuracy is greatly increased*.
- ◆ *Simulation time and computer memory space are also reduced*, allowing for the solution of bigger problems.
- ◆ Advanced calculation techniques are implemented in the CMoM, making possible *simulations from extremely low frequencies (e.g. electric circuits at 50-60 Hz) to very high ones (e.g. Wi-Fi antennas at 2.4 GHz)*.
- ◆ This **extended frequency range** is only available in AN-SOF.

Traditional Method of Moments

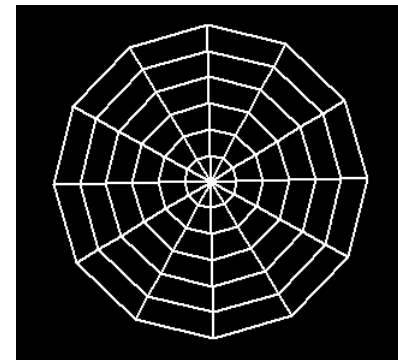

Curved Method of Moments

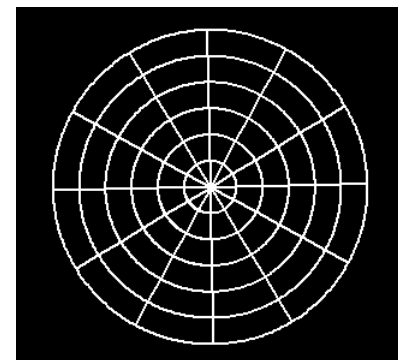

The AN-SOF Input Interface

- ◆ The structure is easily drawn on the screen using dialog boxes for the input data. All wires are placed in 3D space, and several 3D-tools with mouse support have been implemented. *Other softwares use spreadsheets with a lot of geometrical data, which are very difficult to read and edit by users.*
- ◆ Discrete impedances can be placed at arbitrary locations on the structure. Discrete generators and plane waves can be used as excitations.
- ◆ Wire skin effect, perfect and real ground planes, different wire cross-sections, suitable unit systems, frequency sweeps and several visualization options are available.

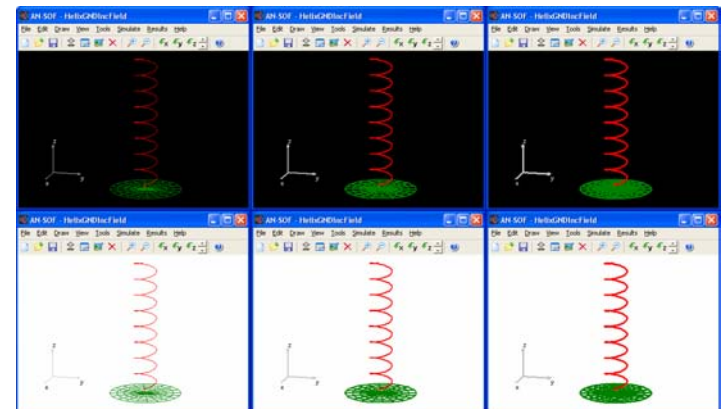
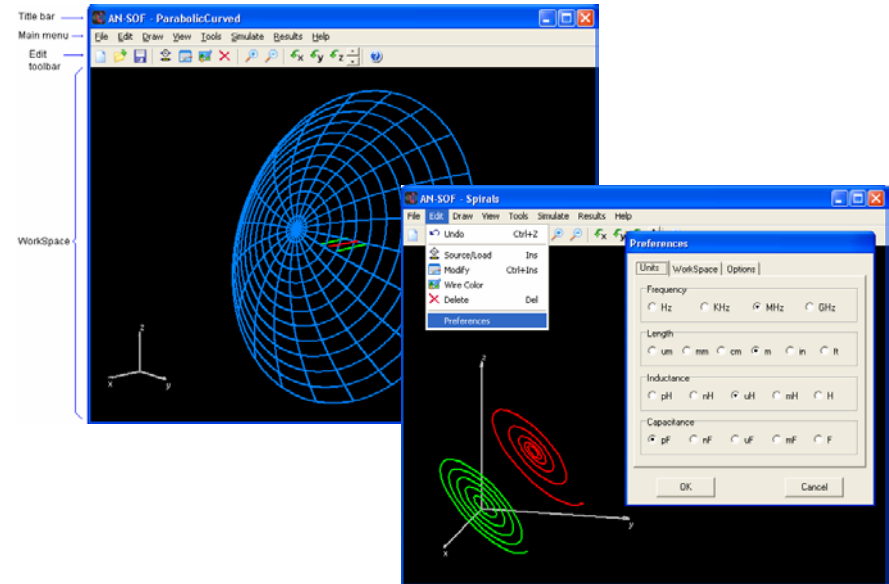

Integrated Graphical Tools

◆ AN-XY Chart



- ◆ Especially designed for the graphical visualization of 2D plots in Cartesian coordinates, such as current distributions vs. position, impedances vs. frequency, and radiation vs. angles.

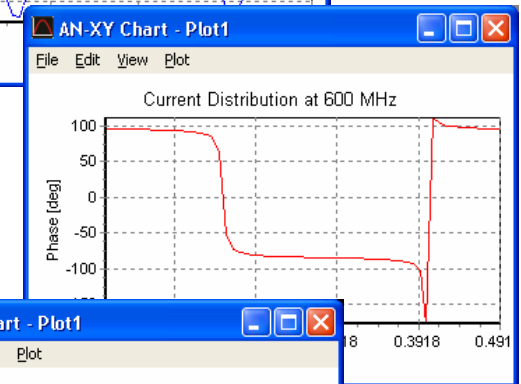
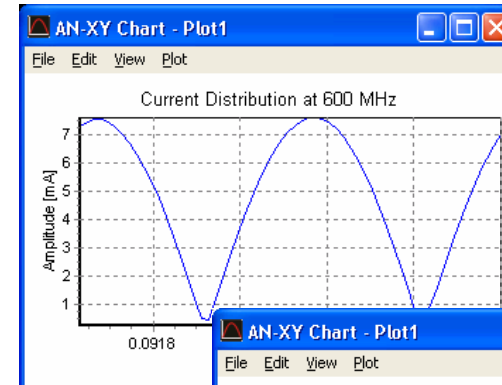
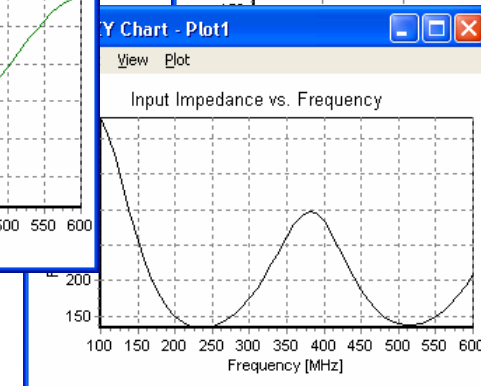
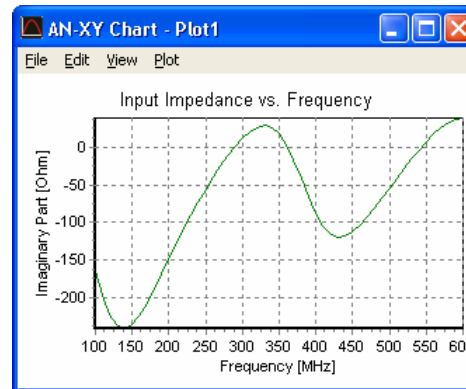
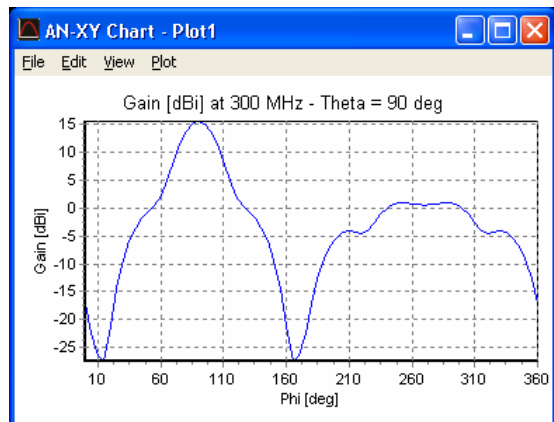

Integrated Graphical Tools

◆ AN-Smith



- ◆ The famous Smith chart for the representation of impedances and admittances is implemented with mouse support for obtaining reflection coefficients and VSWR with only one click.

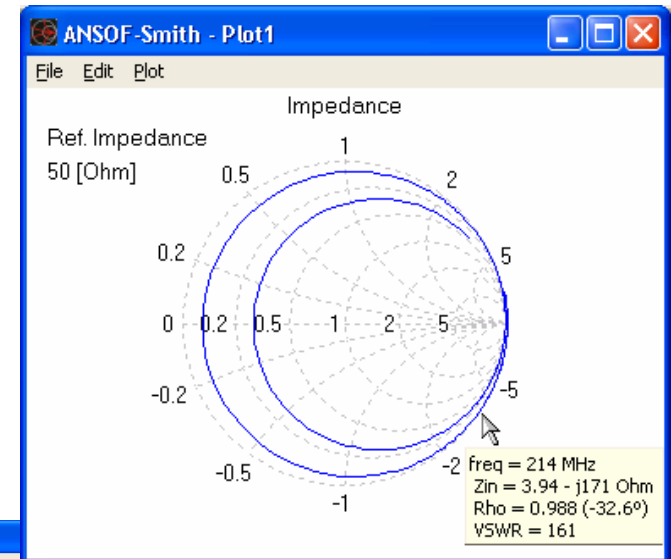
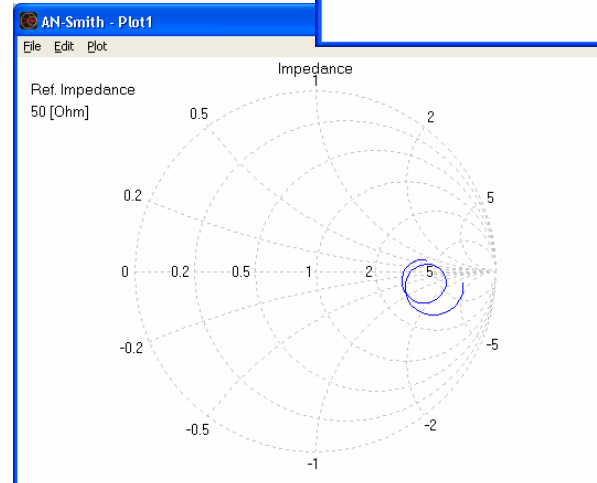
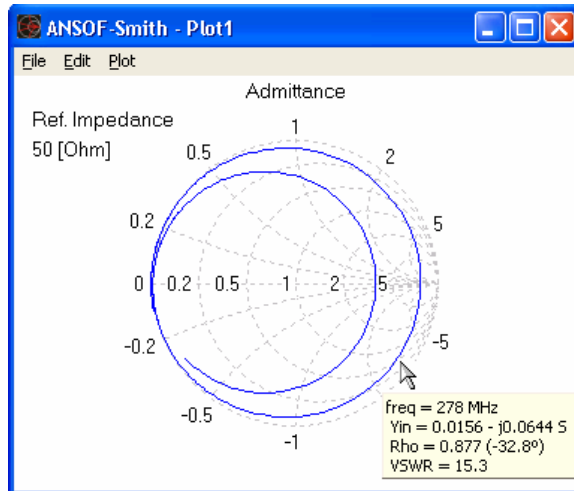

Integrated Graphical Tools

◆ AN-Polar



- ◆ The widely used polar diagram for the representation of electromagnetic fields versus azimuth and zenith angles.

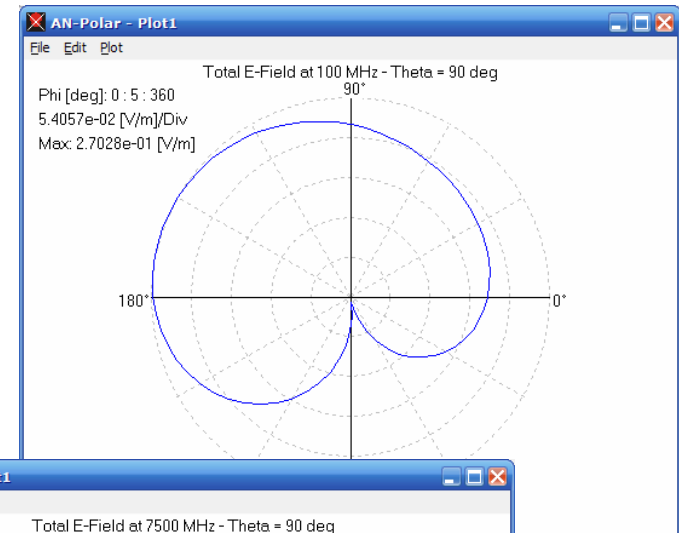
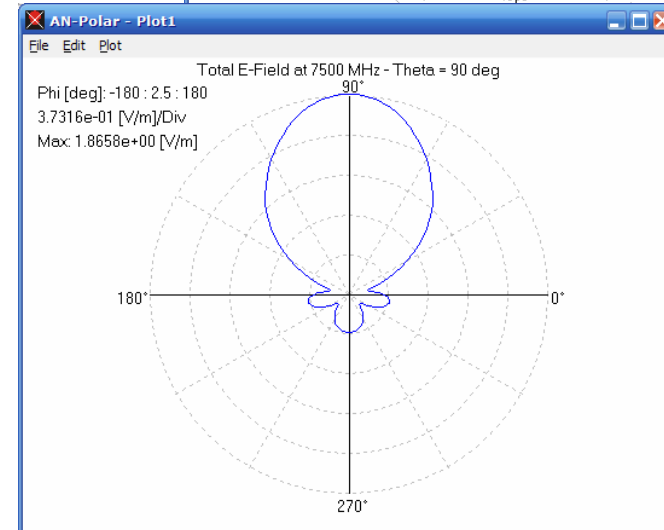
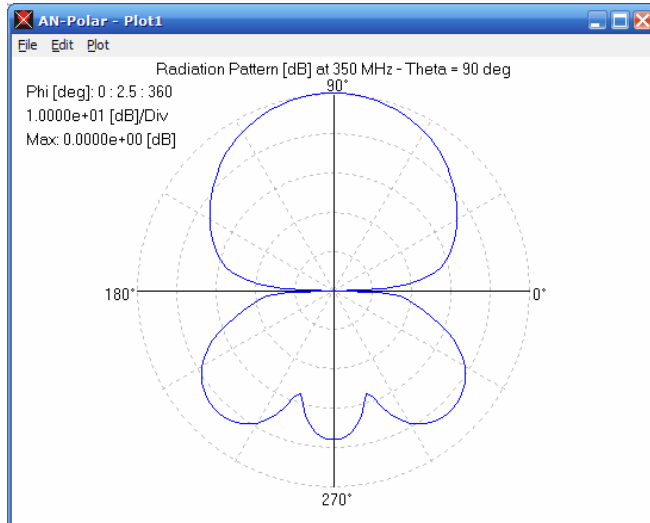

Integrated Graphical Tools

◆ AN-3D Pattern



- ◆ A 3D view of radiation and scattering patterns can easily be handled with this graphical tool, including colored surfaces and bar scale, zoom and rotation functions.

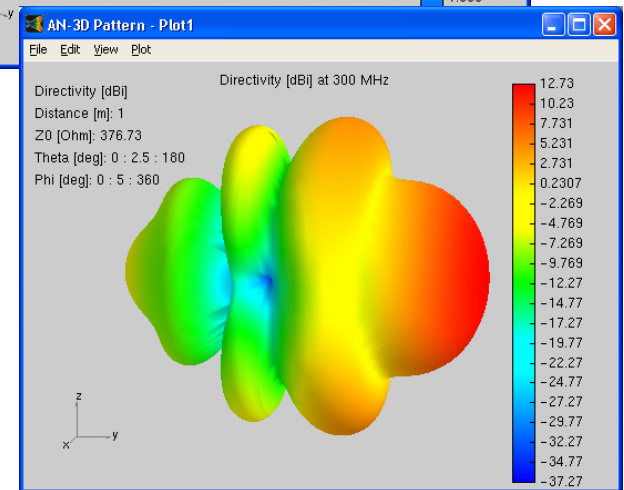
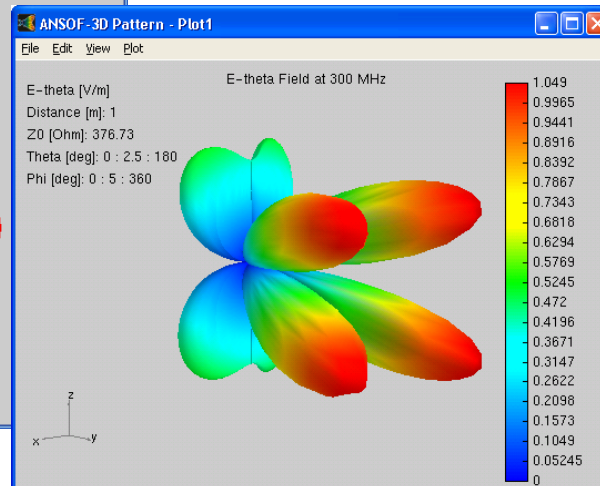
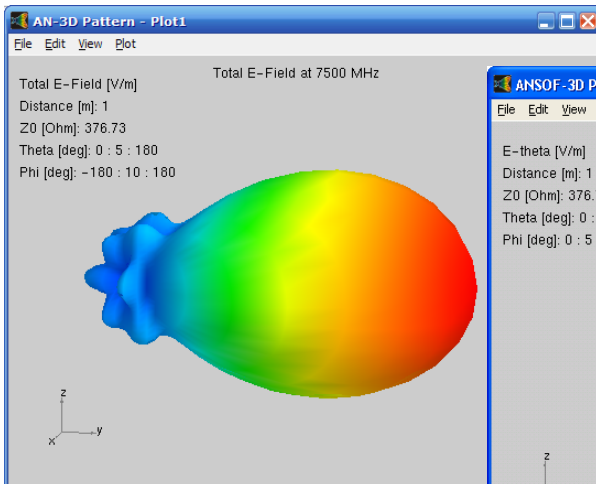
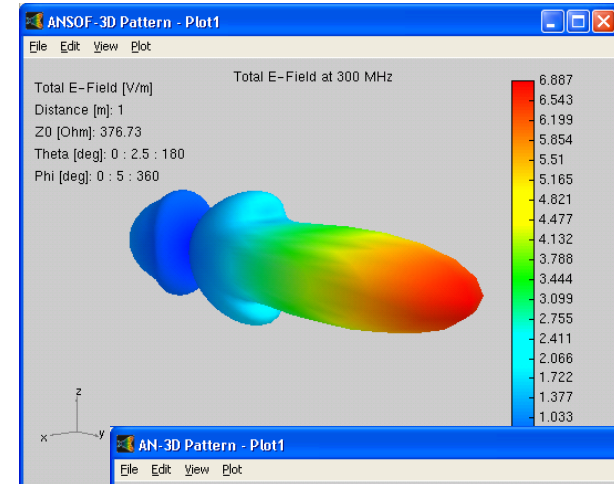

Examples

AM Antenna

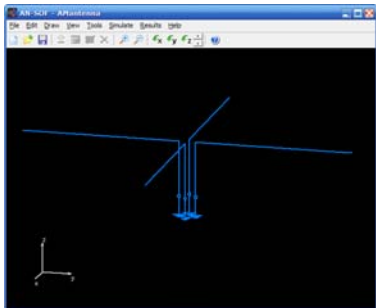

Yagi-Uda

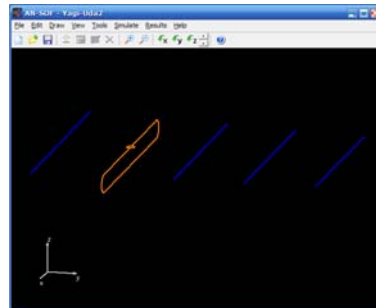

Log-Periodic

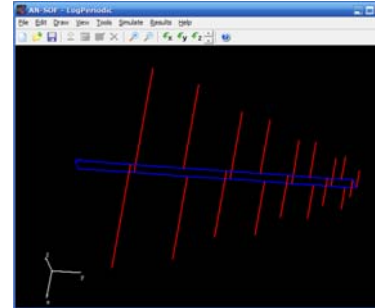

Multi-hole Coupler

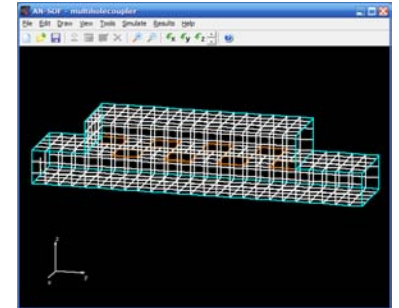

Grid Reflector

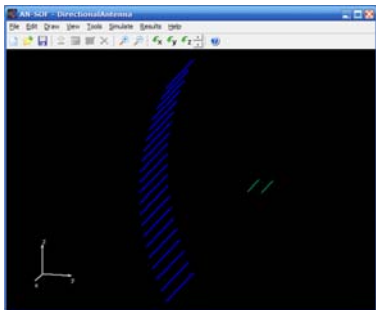

Horn Antenna

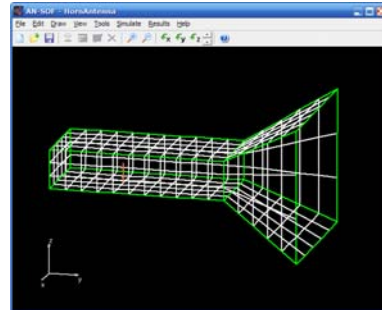

Parabolic Antenna

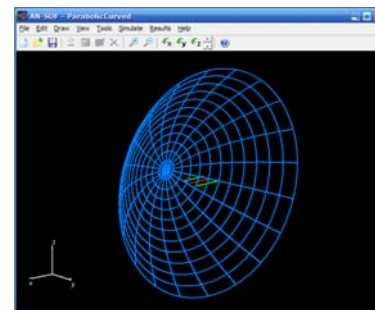

Magic Tee

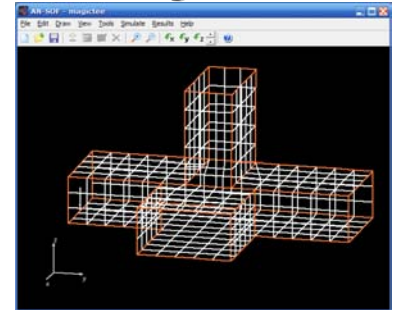

Helix Antenna

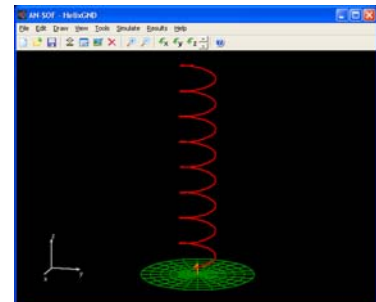

Patch Antenna

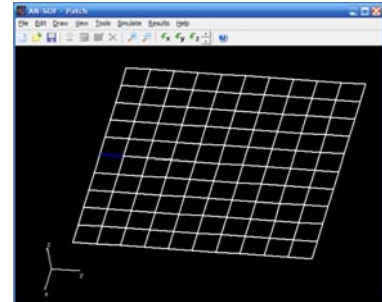

V-Antenna

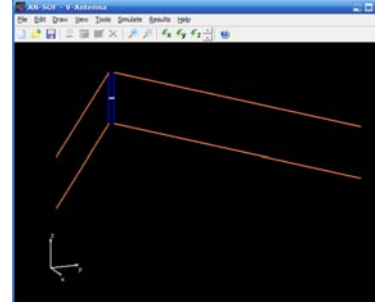

Waveguide

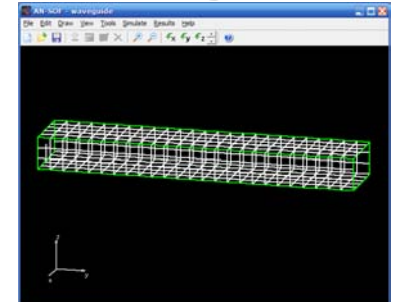

Simulation has never been so easy!



AN-SOF
Antenna Software

AN-SOF Professional v2.6®

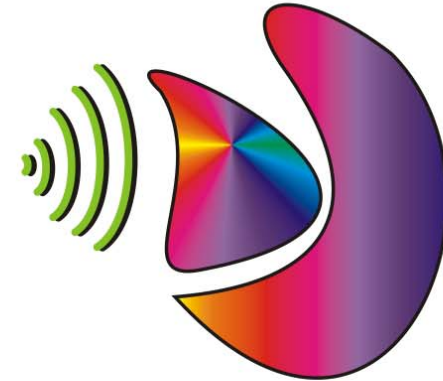

Copyright © 2000 | Golden Engineering

www.antennasoftware.com.ar

info@antennasoftware.com.ar